

# HIGH FREQUENCY TRANSIENT SURGE SUPPRESSORS

# ZORC



## FOR PROTECTION OF MEDIUM AND LOW VOLTAGE MOTORS AND TRANSFORMERS

ZORC is a unique high frequency transient overvoltage surge suppressor for the protection of motors and transformers from steep wave-front, short rise-time, high magnitude, spikes, surges and other transient voltages, generated by switching, lightning and other sources.

The protective characteristics of ZORC:

- Eliminates inter-turn insulation failures
- Extends the life of machine insulation
- Eliminates multiple pre-strike and re-strike transients associated with vacuum and other switchgear
- Provides comprehensive insulation co-ordination at all practical surge magnitudes and rise-times

## Introduction

Every year huge losses are incurred by end-users because of insulation failures of medium voltage (3kV - 40kV) motors, and dry-type transformers. This can be caused by:

Switching transients associated with vacuum and other switchgear resulting in expensive insulation failures of motors and dry-type transformers.

Multiple pre-striking and re-striking (re-ignition) at the motor or transformer terminals.

## ZORC Protection

Provides comprehensive protective characteristics at all practical surge magnitudes and rise-times for insulation co-ordination.

Conforms with both the CIGRè and IEEE motor impulse voltage withstand recommendations, as shown in the additional technical ZORC document as Fig 4.

Halves the magnitude of steep wave-front surges impinging on the load terminals by providing a matched cable terminating impedance under transient conditions, thereby eliminating refraction of steep wave-front surges (i.e. eliminates voltage doubling effects).

Eliminates multiple pre-striking and re-striking transients associated with vacuum and other switchgear, by eliminating reflections of the pre-strike and re-strike current wave-fronts, and thus preventing high frequency current zeros in the contact gap of the switch.

## Benefits provided by ZORC

Saves money by eliminating production downtime incurred due to insulation failures of motors and dry-type transformers.

Protects new motors and dry-type transformers throughout their service life.

Extends the life of motor and dry-type transformer insulation if retrofitted to existing motors and dry-type transformers in service.

## ZORC Product Features

### Models to suit various voltages

400V to 40kV.

### ZORC versions

Available in single phase and three phase units. Single-phase versions are suitable for installing in phase segregated terminal enclosures.

### Compact and easy to install

Special compact versions that can be fitted within most motor/transformer terminal enclosures or switchgear panels.

### Class 1 Division 2 Certification (ExN, non sparking)

As an option, ZORC surge suppressors may be ordered certified for use in potentially flammable atmospheres, (Class 1 Division 2 locations), temperature classes T1 to T5, to SABS 970-1971 (amended).

### Well proven

Thousands of ZORC surge suppressors have been installed over the past 20+ years, on motors, generators and transformers, solving the problem of insulation failures and attendant repair and downtime costs.

## Applications

### Installed in the following industries:

- Chemical.
- Petrochemical.
- Underground mining (gold, platinum, coal, other).
- Surface mining (coal, copper, uranium, iron ore, other).
- Metal beneficiation (steel, stainless steel, gold, platinum, copper and uranium refineries).
- Power generation (generators, power station auxiliaries).
- Pumping (water pumping stations, oil pipelines).

### Applied

Specific applications on medium voltage motors, generators, and dry-type and oil immersed transformers:-

- Fans.
- Pumps.
- Compressors.
- Mills.
- Crushers.
- Refrigeration machines.
- Motor-generator sets.
- Mine winders.
- Conveyors.
- Underground and surface mini-substations and mobile substations.
- Generators.
- Power station auxiliaries.
- Induction & arc furnaces.
- Dry type transformers.

## Available Types

ZORC type: Number

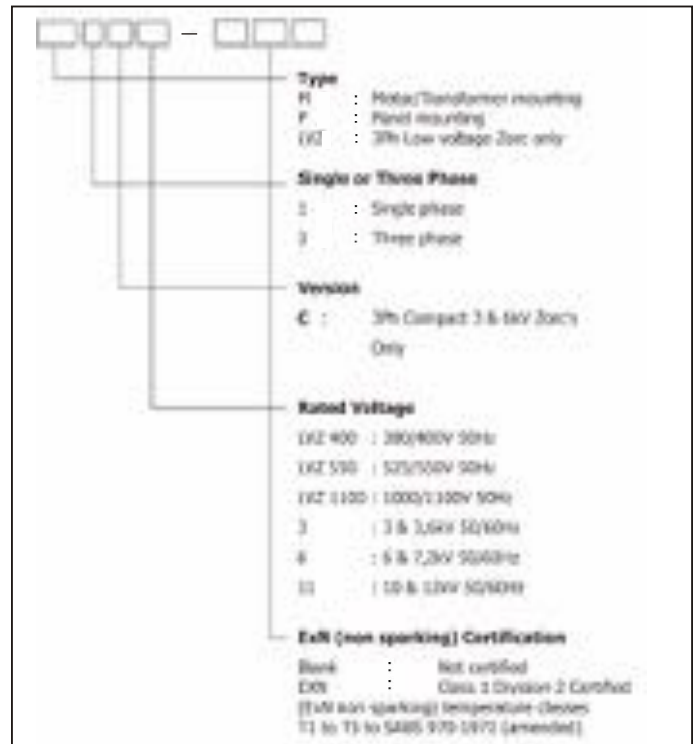

Ordering Examples:  
ZORC type M3-11KV-EXN  
ZORC type P3-3KV

### STANDARD ZORC - medium voltage

- M1-3kV use on 3.3kV 1 phase 50/60Hz systems
- M1-6kV use on 6.6kV 1 phase 50/60Hz systems
- M3-3kV use on 3.3kV 3 phase 50/60Hz systems
- M3-6kV use on 6.6kV 3 phase 50/60Hz systems
- M1-11kV use on 11kV 1 phase 50/60Hz systems
- M3-11kV use on 11kV 3 phase 50/60Hz systems
- M1-15kV use on 15kV 3 phase 50/60Hz systems
- M1-22kV use on 22kV 1 phase 50/60Hz systems
- M1-33kV use on 33kV 1 phase 50/60Hz systems
- M1-40kV use on 40kV 1 phase 50/60Hz systems

Note: The prefix M indicates a motor mounting Zorc while a prefix P indicates a panel mounting Zorc. Other voltages on request.

### COMPACT ZORC - medium voltage

- M3C-3kV use on 3.3kV 3 phase 50/60Hz systems
- M3C-6kV use on 6.6kV 3 phase 50/60Hz systems

The compact ZORC is a 3 phase design fitted with 1 metre high voltage silicone rubber flexible leads. This facilitates easy installation into a motor/transformer terminal box and is directly connected to the motor/transformer terminals, thus reducing the required clearance associated with the conventional porcelain bushings.

## LVZ ZORC - low voltage

The low voltage ZORC has three standard models:-

LVZ400 use on 380/400V 3 phase 50Hz systems.

LVZ550 use on 525/550V 3 phase 50Hz systems.

LVZ1100 use on 1000/1100V 3 phase 50Hz systems.

**Note:** ZORC optimised RC surge suppressors are also available as customised designs for 15/24kV, and 30/36kV 3-phase 50/60Hz systems, generally for dry-type transformer and oil immersed arc furnace transformer protection applications.

Certain other, lower, and higher system voltages are available on request.

Enquire from Strike Technologies for further details.

## Accessories

IP55 sheet metal terminal cover with removable gland plate (for cable entry from below), provides a weather-proof, fully metal clad, floor standing enclosure for the ZORC type M3-3/6/11kV, enabling cabling to a motor, generator or transformer terminal box.

Drawings can be supplied for enclosure Types:-

ENC-3/6KV-M3: IP55 enclosure for ZORC types M3-3kV or M3-6kV

ENC-11KV-M3: IP55 enclosure for ZORC type M3-11kV

**Distributed by:**

## Overall mechanical dimensions - guide

Model	Height	Width	Depth
LVZ-400/550/1100	225	224	90
M1-3 & 6kV	190	115	120
M1-11kV/M1-13kV	480	405	135
M3/P3-3 & 6kV	410	405	135
M3/P3-11kV	480	515	105
M3C-3 & 6kV	255	280	110

The above dimensions do not include the clearances required between surrounding equipment and the safe distances for the applied voltages.

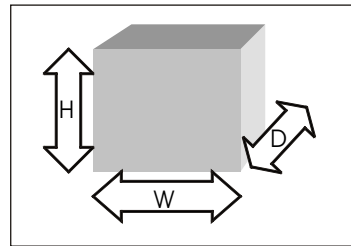

Dimensions and mounting details are available on request from Strike Technologies.

## Refer to ZORC drawings for general specifications

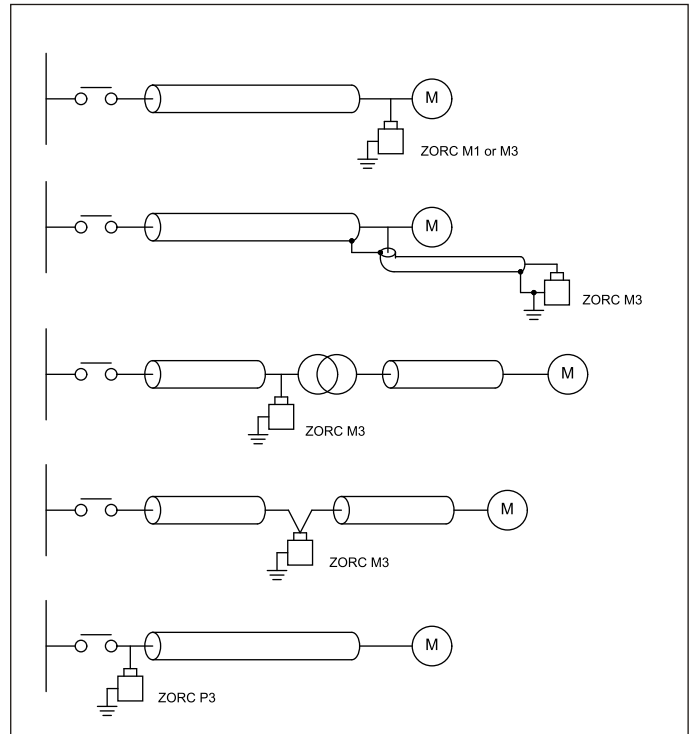

Preferred connections of ZORC surge suppressors

**Zorc Surge Protection**

Zorc technical details for protection of low and medium voltage motors and transformers.

**Steep Wave-Front Surge Problems**

A steep fronted surge comprises a step-change in voltage or current (without reference to earth), with rise-times in the order of 0.1-2µs.

Steep wave-front travelling waves are injected into a cable during the process of switching of motors and transformers, when a pre-strike or re-strike occurs across the closing or opening contact gap of the switch.

Because the motor or transformer load surge impedance is invariably high with respect to the cable surge impedance, the steep wave-fronts are reflected and refracted at the load terminals.

Refraction causes the magnitude of steep voltage wave-fronts to almost double when the wave-front impinges on the load terminals.

During switching, reflection of pre-strike or re-strike current wave-fronts cause high frequency current zeros in the contact gap of the switch. Arc extinction occurs in switchgear capable of interrupting at the high frequency current zeros, and subsequent re-strikes result in the generation of multiple pre-striking transients.

Thus, refraction and reflection of steep wave-fronts, caused by a mismatch of the cable and load surge impedances, is central to the generation of the severe multiple pre-striking and multiple-escalating re-striking switching transients associated with vacuum and other switchgear. (Fig. 1 and 2)

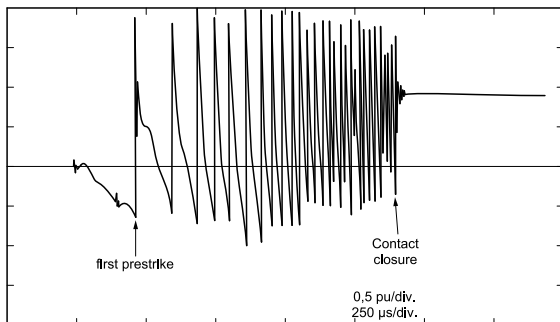

**Fig. 1 Multiple pre-striking during routine motor switch-on.**

*Without ZORC surge suppressor fitted.*  
**Ref: Publication 1.**

**Other Switching Transients**

The following can also occur: -  
 Current chopping and Virtual current chopping transients. The former is normally not severe because the voltage transient generated is not steep fronted, and the normal chopping currents of medium voltage switchgear are not high.

The latter is extremely severe and cannot be tolerated by motors and dry-type transformers.

Steep wave-front surges may also be generated by:

Direct lightning strikes, from flashover across insulators, or from induced surges caused by lightning and other atmospheric discharges.

Arcing earth faults on unearthed, reactance, or capacitance earthed power systems.

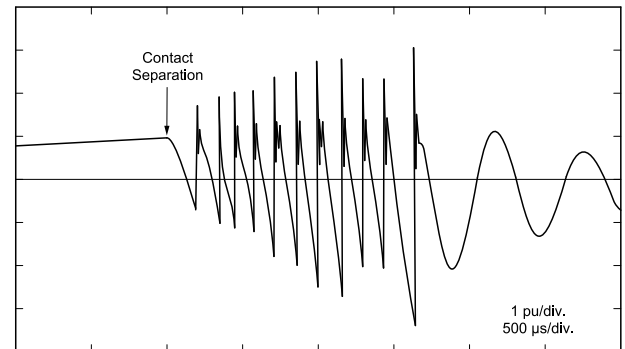
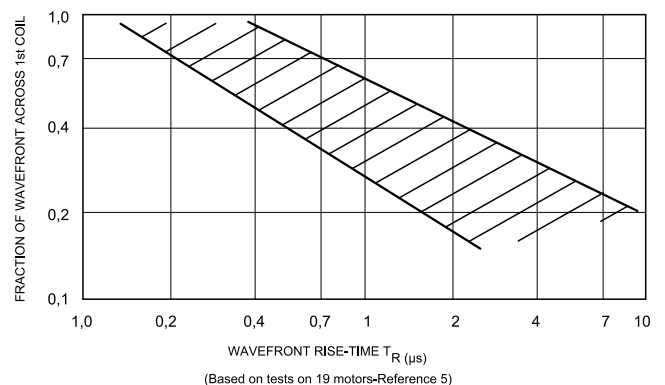

**Fig. 2 Multiple re-striking (re-ignition) during interruption of a motor starting current. i.e. Stalled tripping.** *Without a ZORC surge suppressor fitted.* **Ref: Publication 1.**

**Motor Insulation Impulse Withstand Levels**

The ability of motors and dry-type transformers to withstand steep wave-front switching, lightning and other transient over-voltage phenomena is the lowest of all equipment generally connected to a three-phase power system: -

Because a steep wave-front surge does not distribute itself evenly over the motor/transformer windings, but stresses the line-end coils more, the surge withstand ability of motors and dry-type transformers decreases with decreasing impulse wave-front rise-times, i.e. the steeper the surge wave-front, the more the stressing of the inter-turn insulation of the line-end coils. (Fig. 3)



**Fig. 3 Percentage of voltage wave-front appearing across line-end coil as a function of rise-time.** **Ref: Publication 5.**

- This contrasts with the protective characteristics of power surge arresters, which exhibit an increasing (or at best, a constant) spark-over/residual voltage characteristic for steeper impulse wave-fronts i.e., it is impossible for power surge arresters to provide adequate insulation co-ordination at all practical impulse magnitudes and rise-times.
- In addition, power surge arresters provide protection with respect to earth, or between phases, whereas steep wave-front surges are step changes in voltage without reference to earth (often crossing earth potential) which stress the inter-turn insulation of the line-end coils of motors and dry-type transformers. (See Fig. 1 and 2).
- In service, there is an inevitable and unpredictable degradation of motor and transformer insulation as a result of the effects of temperature, vibration, shrinkage of insulation (resulting in loosening of a coil within a slot and subsequent chafing), environmental and atmospheric conditions, the number, magnitude and rise-times of transient over-voltage applied to the motor, etc.

There are no international standards which lay down requirements regarding medium voltage motor insulation impulse withstand levels, either at the point of manufacture or over the intended service life of the motor.

However, the CIGRÉ Working Group 13.02 and the IEEE working group on the impulse strength of AC rotating machines, give some guidance as to what can be expected in practice.

The IEEE curve takes the effects of ageing into account. (Fig. 4)

- Cigré : Withstand level given by 5 manufacturers
- IEEE : Recommended withstand value taking into account ageing.

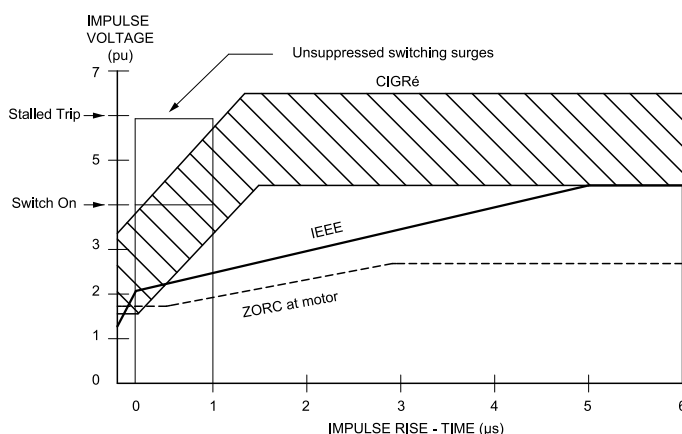

**Fig. 4 Impulses withstand levels of medium voltage motors.**

Showing unsuppressed switching surge magnitudes and rise-times, and insulation co-ordination provided by ZORC.

It is well documented that routine motor switch-on operations can result in surges of up to 4pu with rise times of 0.1 - 1µs, and stalled tripping operations can result in surges of 5 - 6pu with rise times of 0.1 - 1µs.

$$\text{Note } 1\text{pu} = \frac{\sqrt{2}}{\sqrt{3} \cdot V_{L-L}}$$

These surges are significantly higher than the motor withstand levels given by the IEEE and CIGRÉ curves.

(Fig. 4)

### How ZORC Works

The ZORC surge suppressor is a unique voltage and frequency dependent cable-terminating network comprising of, capacitors, resistors and Zinc Oxide (ZnO) non-linear arresters. (Fig. 5)

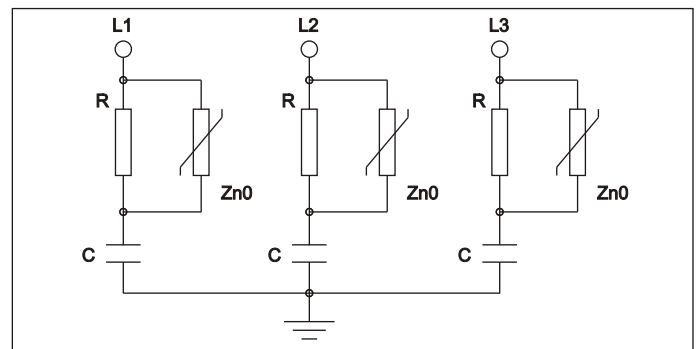

**Fig. 5 Patented ZORC circuit and technique.**

- Normal mains frequency conditions: the impedance of the capacitive elements is very high, effectively "disconnecting" the resistive components from the system and minimising heat dissipation and stressing of these elements.
- High frequency transient conditions: the impedance of the capacitive elements is low with respect to the resistive elements, effectively "inserting" the resistive components in the power system as a cable-terminating network, i.e. voltage refraction and reflection of steep wave-fronts are minimised, voltage doubling is avoided, and high frequency re-strike current zeros in the switch are eliminated when cable terminating resistors have a value of  $Z_c \leq R \leq 3 Z_c$ , where  $Z_c$  is the cable surge impedance.

(Ref: Publication 4.). This eliminates multiple pre-striking and re-striking transients associated with vacuum and other switchgear. (Fig 6 & 7)

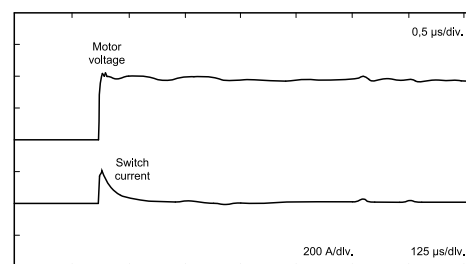

**Fig. 6 Clean switch-on of motor**

With ZORC surge suppressor fitted, showing elimination of multiple pre-striking.

Ref: Publication 1.

**Trigger Point**

Under high magnitude steep wave-front conditions, the ZnO arresters (having a knee-point voltage of 1 - 2 pu) "trigger", providing a very low resistance in series with the capacitive elements, i.e., a suitably low absolute limit is provided to the magnitude of a steep wave-front at the load terminals, and that portion of a steep wave-front which exceeds this limit is sloped to a value within the IEEE recommended motor insulation withstand levels.

**Cable Impedance**

The cable surge impedance  $Z_c$  is independent of cable length, and does not vary widely for different cable types and sizes, i.e., a resistance value of 30 ohms for the ZORC suppressor, satisfying the condition  $Z_c \leq R \leq 3 Z_c$ , is suitable for virtually all installations, and is independent of cable length, motor size and voltage.

**ZORC Heat Dissipation**

The value of Capacitive Elements is optimised to minimise the heat dissipation and stressing of the resistive elements under normal mains frequency conditions while still performing its function as a "frequency dependent switch" and as a "wave sloping capacitor" under high frequency transient conditions.

**ZORC Clamping Voltage**

With the ZORC circuit, ZnO gapless non-linear arresters, with a clamping voltage low enough to protect the inter-turn insulation of the line-end coils,

i.e. less than 2pu, where,  $1pu = \frac{\sqrt{2}}{\sqrt{3} \cdot V_{L-L}}$  can be

used, because the voltage across the non-linear elements is negligible under normal mains frequency operating conditions.

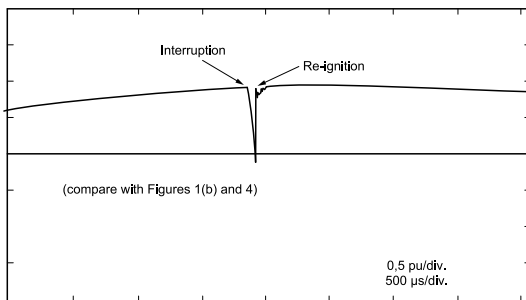

**Fig. 7 Single re-strike during interruption of a motor starting current**

*With a ZORC surge suppressor fitted, showing elimination of multiple escalating re-striking.*

**Ref: Publication 1.**

**Installation**

ZORC surge suppressors may be installed in any orientation (including upside down) on the machine side of the associated medium voltage motor/generator/transformer switch, in the following positions (in order of preference from a surge protection point-of-view): -

- In the motor/generator/transformer terminal box, connected from each phase to earth.
- Cabled to the motor/generator/transformer terminal box via a 3-core cable (25mm<sup>2</sup> minimum), plus earth conductor (in accordance with local regulations).
- In line with the motor/generator/transformer supply cable, shunt connected from each phase to earth.
- In the associated motor/generator/transformer switch panel, connected from each phase to earth.
- Convenient mounting brackets or clamps are provided.

**Connections**

In the case of ZORC surge suppressors with porcelain bushings, care should be taken to use flexible connections to the bushings to avoid vibration or shock being transmitted to the bushings, in service and during transportation (when pre-wired). In addition, care should be taken not to over tighten the nuts on the bushing and earth studs (maximum 20Nm). Use a spanner to hold the bottom nut while tightening the top nut.

**Flexible Leads**

In the case of ZORC surge suppressors with flexible insulated connection leads (M1-3KV, M1-6KV, M3C-3KV & M3C-6KV), the leads can be cut to length to suit the application, but should not be extended. These compact single-phase motor/ transformer-mounting units must be directly connected to the machine terminals.

**Earth**

Be sure to earth the ZORC suppressor earth stud to the machine earth or switchgear panel earth bar, and ensure the machine is earthed back to the system earth via the machine's cable earth conductor, in accordance with local regulations.

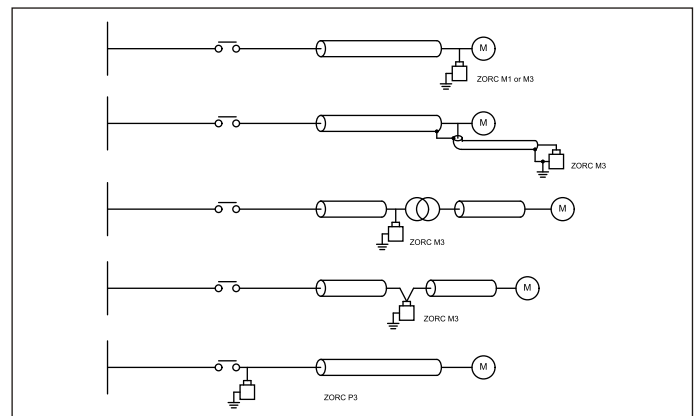

**Fig. 8 Preferred connections of ZORC surge suppressors**

▶ **Publication references**

**Refer Publication 1 EPCC Report:**

Guide for the Application of Switching Surge Suppressors to Medium Voltage Motors, presented jointly by the South African Institute of Electrical Engineers and the Electric Power Co-ordinating Committee, at a seminar held on 19 August 1992.

**Refer Publication 2 Yelland, CP:**

New Developments in the Protection of Medium Voltage AC Motors from Steep Fronted Surges, SAIEE Industrial Power System Disturbances Symposium Proceedings, September 1983.

**Refer Publication 3 Pretorius, RE:**

Optimised Surge Suppression of High Voltage Vacuum Contractor Controlled Motors, IEE International Conference on Sources and Effects of Power System Disturbances, London, May 1982.

**Refer Publication 4 Pretorius, RE:**

The generation of travelling waves in cable connected motor circuits and the effects thereupon of RC surge suppression circuits, CSIR Special Report ELEK 90, December 1980.

**Refer Publication 5 Nailen, RE:**

Transient surges and motor protection. Ind. And Com. Power System Tech. Conference, Seattle, 1979.

**Distributed by:**

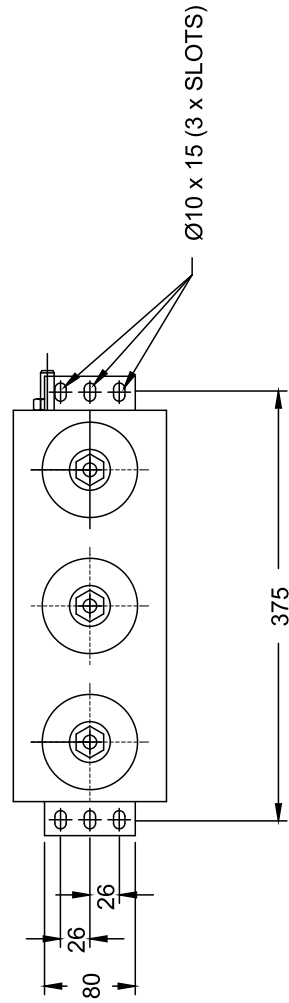
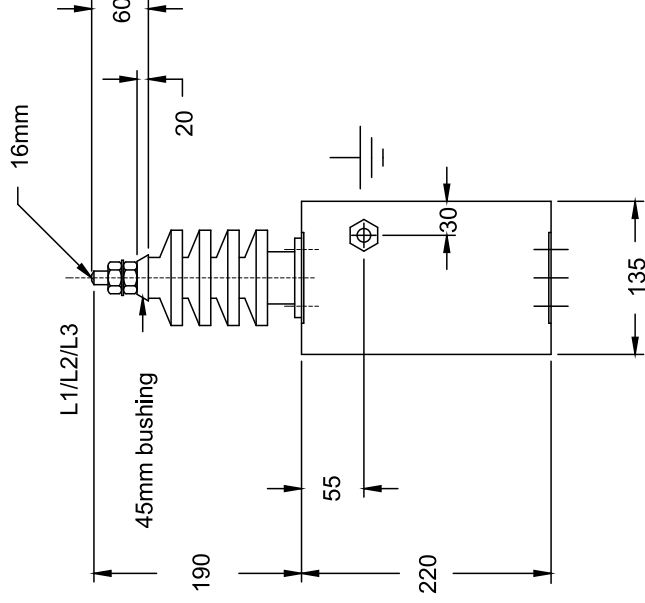
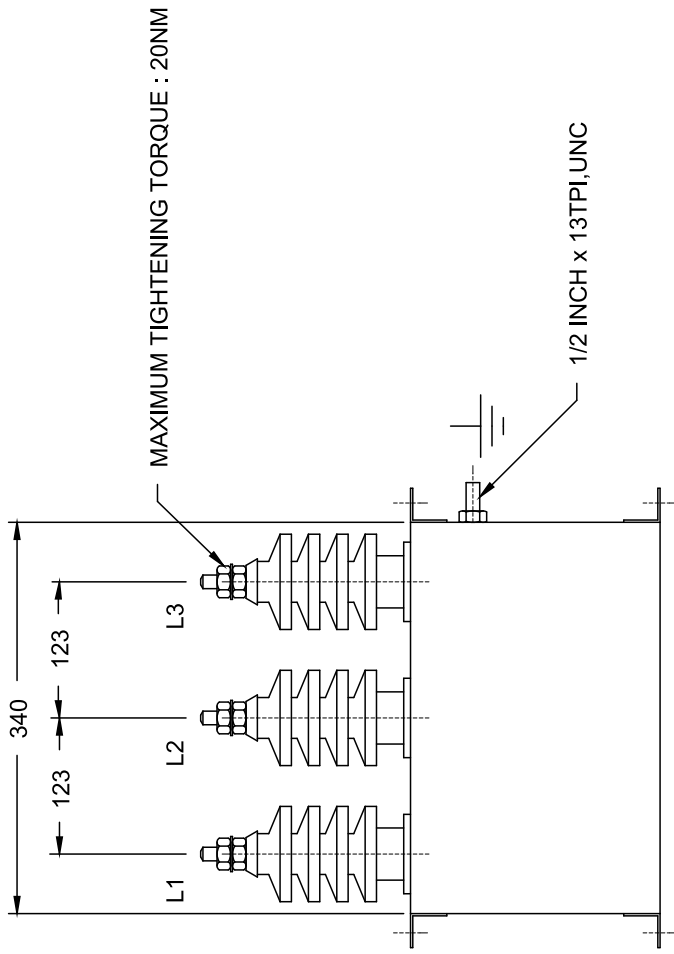

CLEARANCE BETWEEN PHASES : 78mm  
 CLEARANCE TO EARTH : 110mm  
 CREEPAGE TO EARTH : 190mm  
 BUSHING BIL : 75kV peak  
 BUSHING AC WITHSTAND : 60kV dry 1 minute  
 : 45kV wet 10 second

MASS : 16kg

TOLERANCE : ±5 TYPICAL ALL OVER

HOLE : +1  
 -0

Date:

2003-11-01

NAME:

ZORC SURGE SUPPRESSOR  
 TYPES : M3-3kV, M3-6kV  
 P3-3-kV, P3-6kV

Drawing No.

ZORC1.DWG



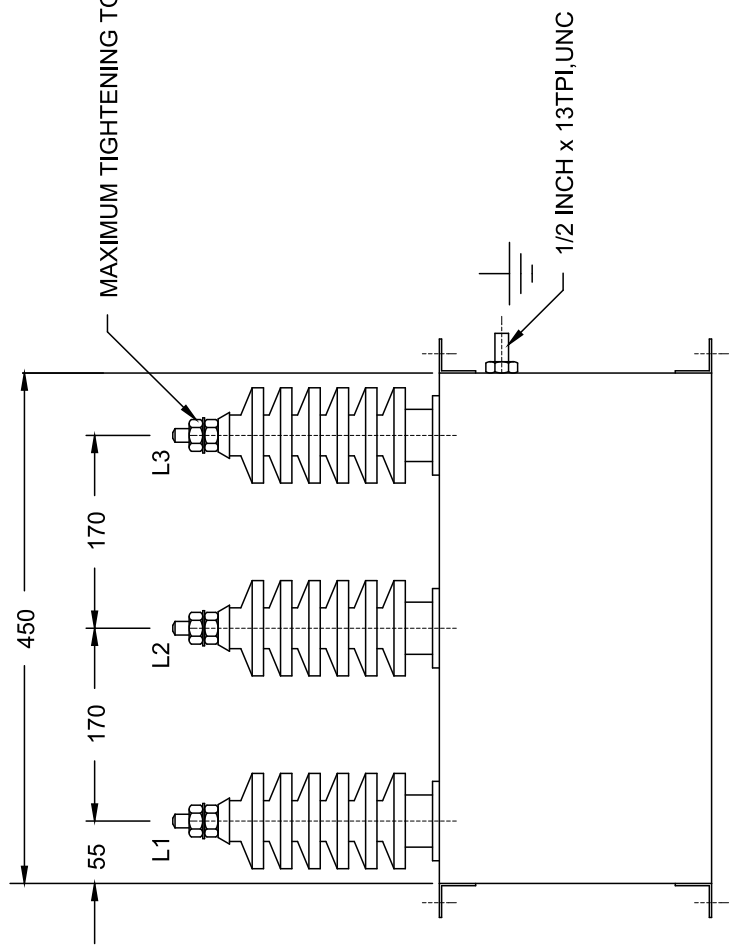
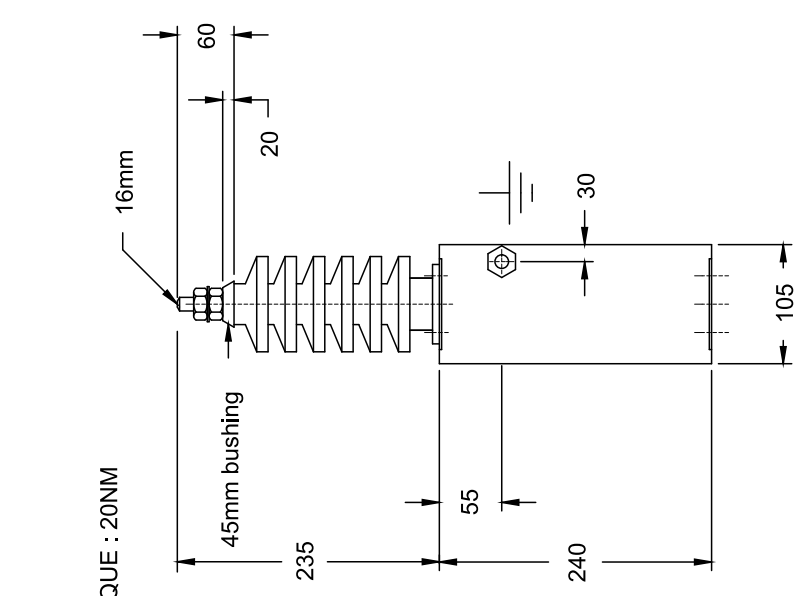

- CLEARANCE BETWEEN PHASES : 125mm
- CLEARANCE TO EARTH : 165mm
- CREEPAGE TO EARTH : 305mm
- BUSHING BIL : 95kV
- BUSHING AC WITHSTAND : 70kV dry 1 minute  
: 50kV wet 10 second
- MASS : 19kg
- APPLICATION : INDOORS
- TOLERANCE : ±5mm TYPICAL ALL OVER
- HOLE : +1  
-0

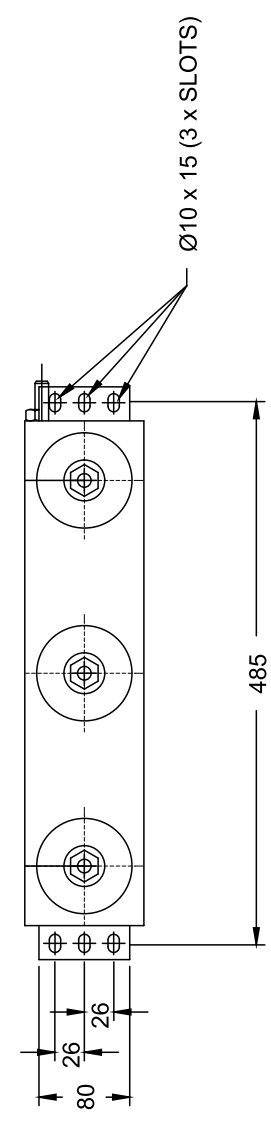

Date:	2003-11-01	Name:	ZORC SURGE SUPPRESSOR TYPES : M3-11kV P3-11kV
		Drawing No.	ZORC2D.DWG



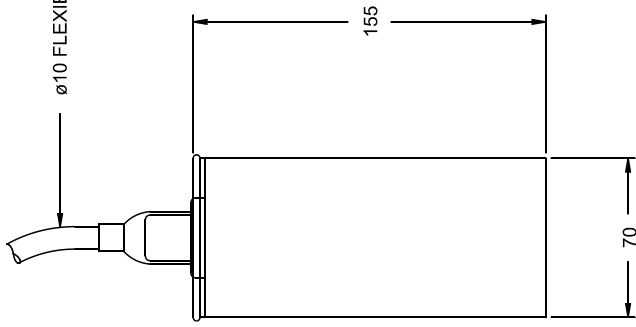
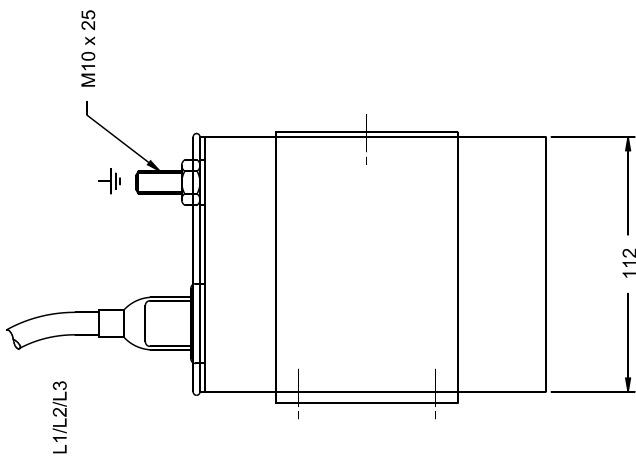

ø10 FLEXIBLE 11KV INSULATED CONNECTION LEAD 600mm LONG

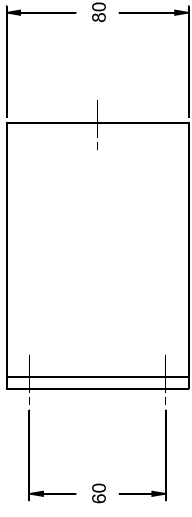

MOUNTING BRACKET

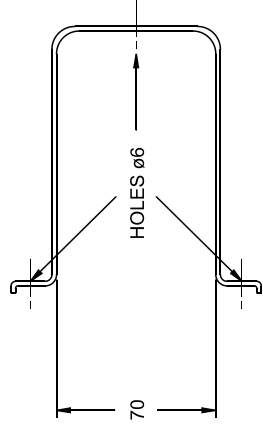
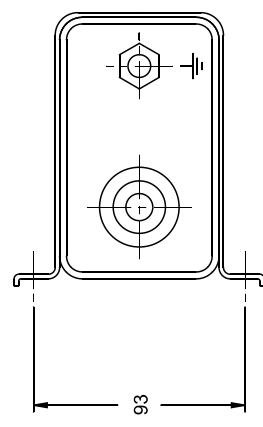

MASS 1,75 Kg.

Date:

01 / 08 / 92

Name:

ZORC SURGE SUPPRESSOR  
TYPES : M1-3KV, M1-9KV  
WITH MOUNTING BRACKET

Drawing No.

ZORC3.DWG



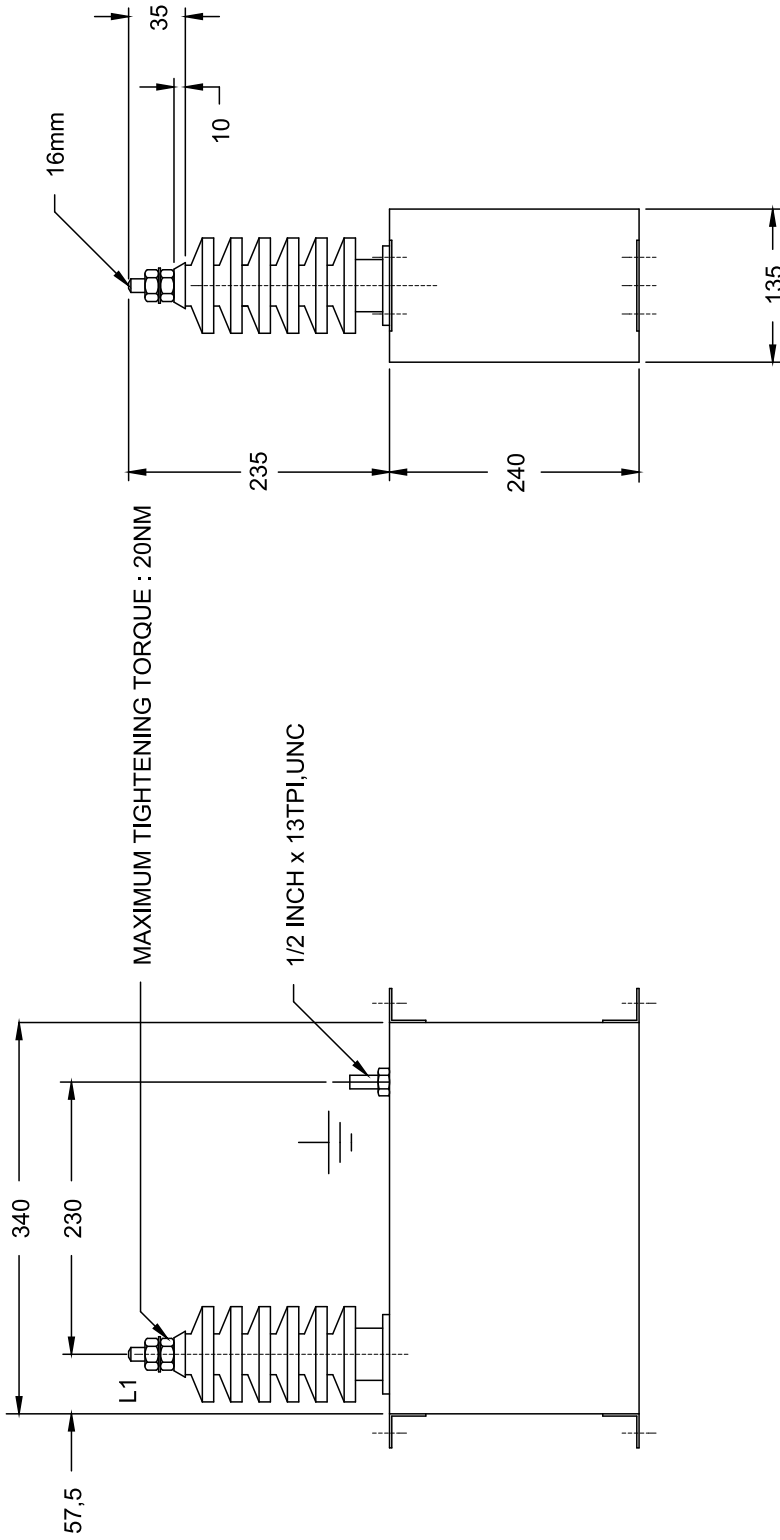

MAXIMUM TIGHTENING TORQUE : 20NM

1/2 INCH x 13TPI,UNC

- CLEARANCE TO EARTH :165mm
- CREEPAGE TO EARTH :305mm
- BUSHING BIL :95kV
- BUSHING AC WITHSTAND :70kV dry 1 minute
- :50kV wet 1 second
- MASS :15kg
- APPLICATION :INDOORS OR OUTDOORS
- TOLERANCE 5mm
- HOLE +1
- 0

Date: 2003-11-01

Name: ZORC SURGE SUPPRESSOR  
TYPE : M1-11kV/M1-13kV



Drawing No. ZORC4A.DWG

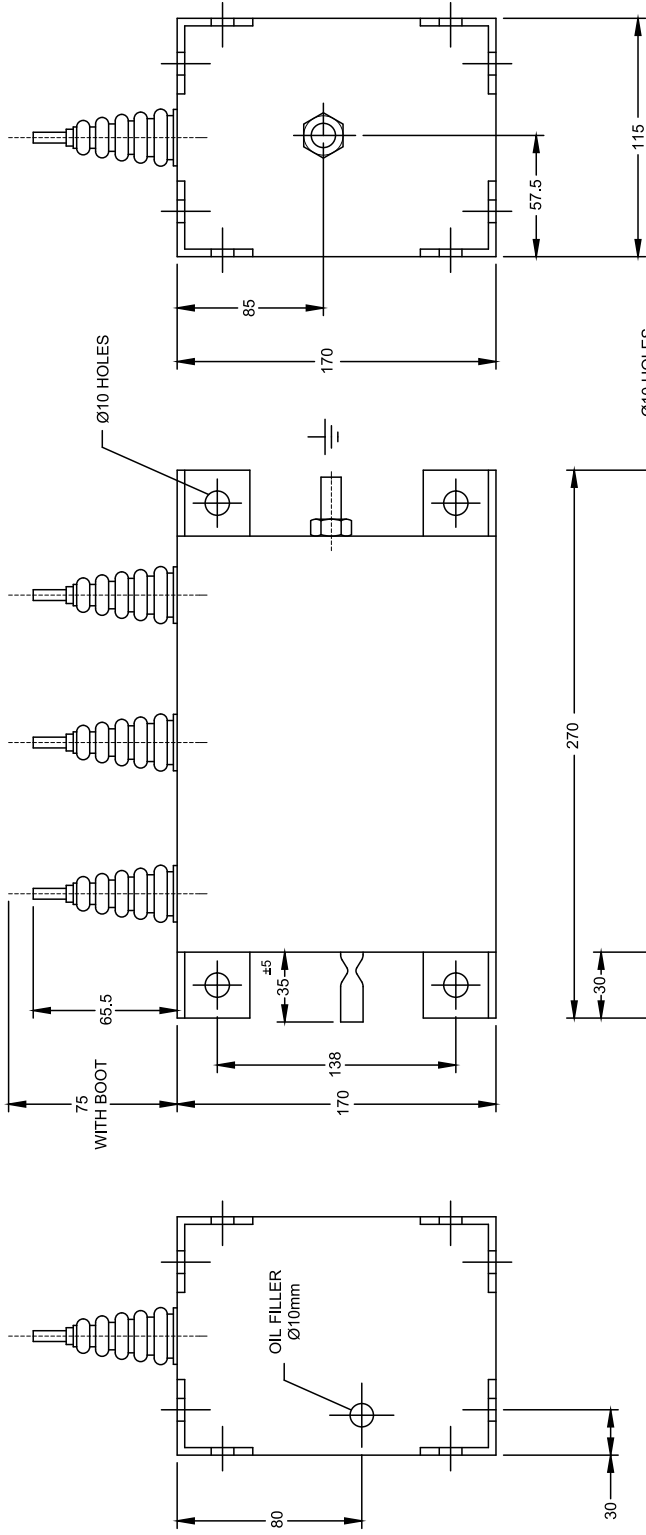

MASS : 5.8kg  
 TOLERANCE : ±5mm TYPICAL ALL OVER  
 HOLE : +1  
 -0

FLEXIBLE 11kV  
 INSULATED LEADS  
 M10 EARTH STUD 25mm LONG

Drawing No. ZR_MD0002A.DWG	Name: ZORC GA FOR ZORC TYPES M3C-6KV AND M3C-3KV		Date: 07 / 09 / 99
-------------------------------	---	---	-----------------------

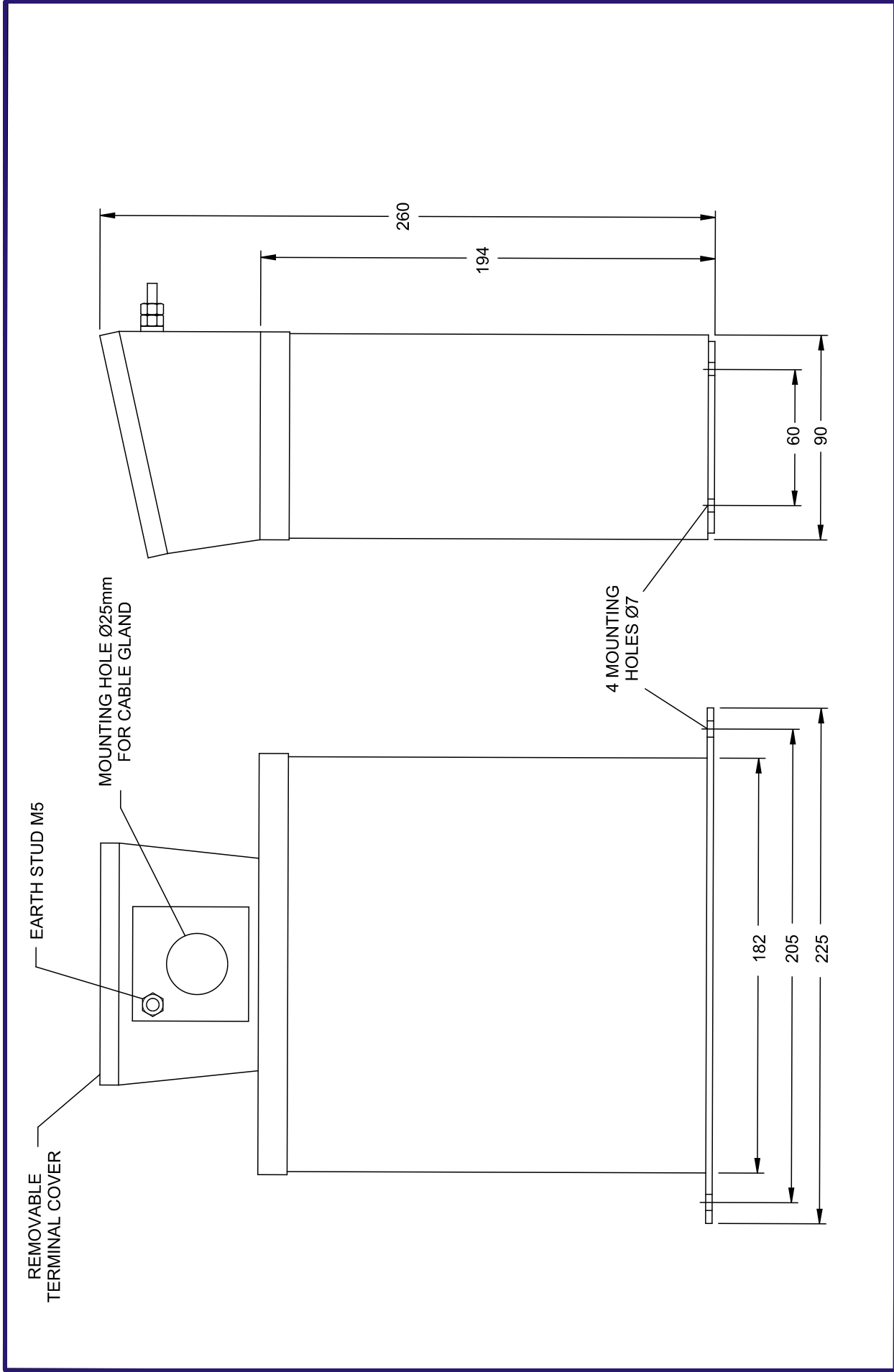

Date:

01 / 07 / 96

Name:

LV ZORC  
OUTLINE DIMENSION

Drawing No.

GA01.DWG



---

**APPLICATION: ZORC - PROTECTION OF MOTOR & TRANSFORMERS FROM SWITCHING SURGES**  
**\* Function & Testing**

---